

Condensate Safety Overflow Switch for Primary Drain Pans

Cuts power to an air conditioning system when a clog or backup occurs, preventing water damage

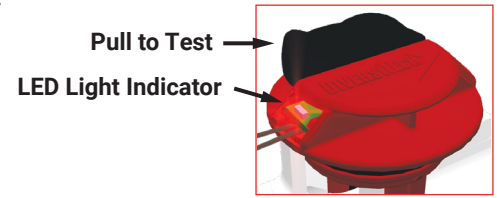

STEP 1: CS-1 Installation Configuration Examples for Primary and Auxiliary Applications

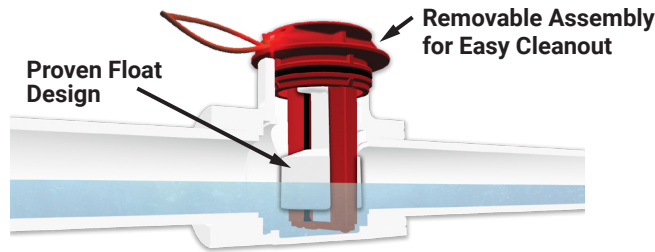

FIG. A: PIPE INLINE

Glue the 1" x 3/4" reducer bushing (3) to the pipe tee (2). Glue pipes to the 3/4" ports. Insert the sensor assembly (1) into the pipe tee and press firmly. Do not glue sensor assembly on to the pipe. Ensure that the sensor is not tilted more than 30°. (Refer to FIG. D)



FIG. B: 90 DEGREE

Glue the 1" x 3/4" reducer bushing (3) to the pipe tee (2). Glue pipes to the 3/4" ports. Insert the sensor assembly (1) into the pipe tee (2) and press firmly. Do not glue the sensor assembly on to the pipe. Ensure that the sensor is not tilted more than 30°. (Refer to FIG. D)



FIG. C: ON DRAIN PAN

Insert the threaded fitting (5) into the drain pan. Glue the threaded fitting (5) into the 1" x 3/4" reducer bushing (3) and the pipe tee (2). Glue the PVC cap (4) into the pipe tee (2). Insert the sensor assembly (1) into the pipe tee (2) and press firmly. Do not glue the sensor assembly on to the pipe. Ensure that the sensor is not tilted more than 30°. (Refer to FIG. D)

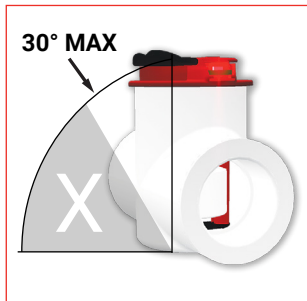
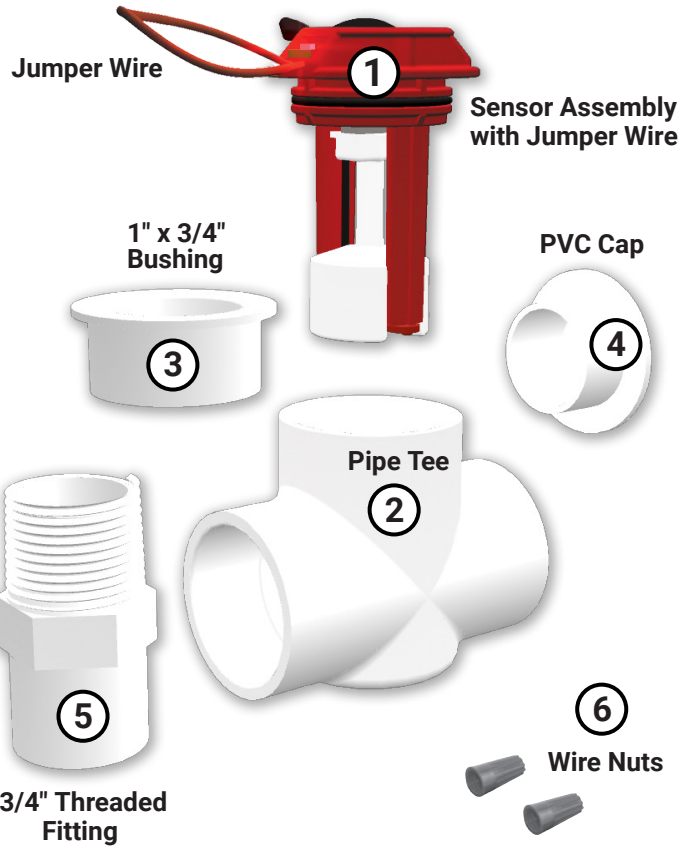
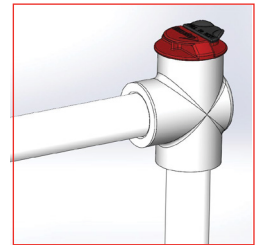
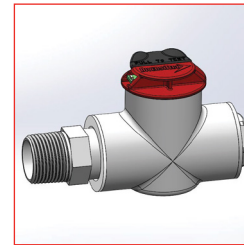
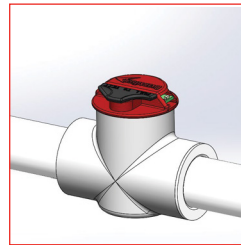

FIG. D: SENSOR TILT THRESHOLD



THREE INSTALLATION CONFIGURATIONS



STEP 2 and 3: Verifying Correct Installation

STEP 2: The sensor can be wired in series to break control voltage (typically either the red or yellow wires. (Refer to FIG. E). Max current: 1.5 amp.

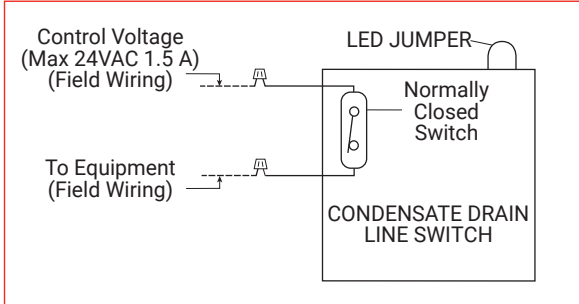

FIG. E: WIRING DIAGRAM

STEP 3: Use the "Pull To Test" lever to test functionality and confirm that LED is on when lever is up. Press down on the "Pull To Test" lever to ensure that it is flush with the housing. (Refer to FIG. F)



FIG. F: USING "PULL TO TEST" LEVER

SHUTDOWN TESTING MUST BE PERFORMED FOR EACH INSTALLATION TO ENSURE PROPER SWITCH OPERATION.

⚠ IMPORTANT INFORMATION REGARDING THE JUMPER WIRE

- The CS-1 uses a very small current to light the LED
- Some HVAC systems will not shut down when the CS-1 LED is illuminated
- In the event the HVAC system does not shut down when verifying installation (Step 3), cut jumper wire and insulate both ends with either wire nuts or electrical tape (Refer to Fig. G)
- Cutting the LED jumper will disable the LED
- Once the jumper wire is cut and insulated, repeat Step 3 by pulling the "Pull to Test" lever again to verify proper shutdown

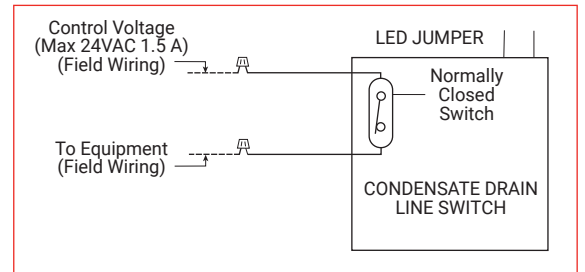

FIG. G: WIRING DIAGRAM WITH CUT JUMPER WIRE

Maintenance & Troubleshooting

Algae and mold growing inside the condensate drain line can restrict the movement of the float inside the housing. It is recommended to clean the float and housing with a mild dish soap solution and a soft or medium brush. Do not use vinegar, bleach, acetone, gasoline, or any other harsh or corrosive chemicals to clean the float or housing. Do not use wire brushes, steel wool, or any other abrasive materials to clean the float or housing.

If the LED light indicator is illuminated and the HVAC system will not turn on, try the following:

- Check and confirm that water is flowing freely through the drain line. Clear any clogs.
- Remove the switch assembly and confirm that the float moves freely inside the housing. If algae growth has blocked the movement of the float, clean it with a brush using a mild solution of water and dish soap.
- Press down on the "Pull To Test" lever to ensure that it is flush with the housing.